



ROADS AND INFRASTRUCTURE SERVICES

Electric Vehicle Charging Strategy Part 1: Introduction and Cost Recovery Model

Author	Project Officer
Owner	Head of Infrastructure
Date	April 2021
Version	1

This document provides **Part One** of Argyll and Bute Council's Electric Vehicle Charger Strategy, this provides the background as to why the Council are setting out a long term plan for Electric Vehicle Chargers, why it is the correct time to do so and how it will tie into wider National Policies.

A brief explanation on the workings of electric vehicles and electric chargers is also provided.

The cost recovery model is set out with explanations for the costs set and what, if any, surpluses will be used for. To ensure there is confidence for electric vehicle users on the availability of charging spaces the Council is also implementing enforcement penalties; section four sets out the penalties and the work the Council will do to update traffic regulation orders across all areas of the Council to ensure consistency.

As the cost model has been newly implemented Part One of the strategy concludes with how and why periodic reviews of charges will be required.

Ultimately the strategy will comprise various parts. It is essential to have a cost recovery model for the current asset group in place initially, prior to consideration of various future aspects of the development of the network.

Part Two will focus on future asset development criteria, with an aim to create various consolidated long lists of potential sites and mid-range cost estimates.

Part Three will give consideration to future funding requirements and options – mapping, application, management – to deliver on the outline programme developed through Part Two.

Part Four will cover management and maintenance of the developing network over time, with a focus on sustainable asset management.

Part Five will provide a procurement and installation strategy, with a focus on best value in the delivery process, including electricity tariff applications and ongoing monitoring etc.

Part 1: Introduction and Cost Recovery Model Table of Contents

1. Introduction	
• Background	page 4
• Purpose of Strategy	page 5
• Links to National Priorities and Strategic Framework	page 6
2. Understanding electric vehicles and chargers	page 9
3. Charging Regime	page 12
• Cost Breakdown	page 13
4. Enforcement Penalties	page 16
• Traffic Regulation Orders	page 17
5. Potential Future Costs	page 18
• Charging Review	page 19

1. Introduction

This is part one of the Councils Electric Vehicle Charging Strategy; the Charging Regime. The following details why the Council are providing publically accessible charging points and why a charging strategy is now required.

Subsequent stages to follow will focus on the future asset development criteria, future funding opportunities, management and maintenance of network, installation planning and project management and the ongoing review of income

The expectation is that the National Government will provide significant levels of funding for this area of work in future years, therefore it is important that the Council has a thorough strategic development plan.

1.1 Background

In 2017 the Scottish Government set out an ambition to reduce Scotland's emissions of greenhouse gasses and to phase out the need for new petrol and diesel cars and vans by 2032. This strategy sets out how Argyll and Bute Council will provide a sustainable network of publicly available Electric Vehicle (EV) chargers and assist with meeting the national target of reducing the impact of climate change.

The Scottish Government via Transport Scotland allocated capital funding for local authorities to invest in the Electric Vehicle (EV) Charger infrastructure with the initial expectation that revenue costs would be absorbed by councils. Through this EV users have been able to charge their vehicles free of charge, despite this incurring a number of fixed and variable costs for the Council. Free to charge was a policy decision by Scottish Government to encourage the uptake of the technology to support targets for the reduction of carbon emissions and combat climate change; it has also been a condition of the grants from Transport Scotland to make charging sites free and publicly accessible. While this approach may have been suitable in the short-term, with the increasing popularity of electric cars, and the continued reduction in local government funding, the Council agreed at its budget meeting of February 2020: *Reflecting Transport Scotland advice, agrees that a charging regime should be developed for all Electric Vehicle Charging Points with charging for 2020/21 to be on the basis of electricity consumption cost recovery and a report on the long-term approach to come to the September 2020 meeting of the Environment, Development and Infrastructure Committee.*

With popularity of EVs on the rise and as more charging units are being installed it is not feasible to continue to provide free electricity, to date there have been over 35,000 charging sessions on the Councils network. Wider strategic commitments to decarbonise the transport network in line with climate change targets will also add to ongoing expansion of the EV charging network therefore continuing to cover the costs of electricity and ongoing maintenance will lead to increased pressure on already stretched Council budgets.

To reduce the financial pressure on the Council of providing free electricity to EV users a fair, robust and equitable charging regime for the publically accessible Electric

Vehicle Charging Points is required; with charging being based on electricity consumption and future maintenance cost recovery. The financial sustainability of the existing network is the focus of the first part of this strategy, with the second part focussing on the management of the current network e.g. advertising and enforcement of the cost recovery model. Latter parts to focus on a future implementation programme, the process around future funding models, a long-term plan for reinvesting in the network and how communities/community groups will be supported in taking forward their own schemes.

EVA (Electric Vehicle Association) Scotland has proposed tariff guidance for private and publicly accessible charging units however as there is currently no standardisation across Scotland. We have benchmarked where possible against other local authorities who have implemented an EV charge in line with EVA guidance.

1.2 The main purposes of the strategy are:

- To determine how the asset group becomes self-funding in terms of future revenue costs. To achieve this we utilize information from the Energy Savings Trust and benchmark, where possible, against other local authorities to understand their charging regimes and any sliding scale of charges applied. Factoring in the need to generate a surplus over and above pure energy costs to reinvest in maintenance and associated infrastructure.
- To support practices that encourage appropriate behaviours that maximise utilisation and availability of charge points; whether it is reasonable to charge for use of a parking space over and above the use of the charger and how this will be enforced.
- To identify potential locations for new installations and a set of agreed criteria to assess each site, determining the feasibility and how many in any given location.
- To explore future funding opportunities and the possibility of community ownership and to establish the process for public and Council installations

This strategy must

- Contribute to national priorities
- Provide clear links to local strategic plans, particularly the Council's decarbonisation plan
- Reflect the views, contributions and needs of stakeholders
- Determine the best price to apply for accessing electric vehicle charge points throughout Argyll and Bute

1.3 Links to National Priorities Strategic Framework

National and Local Priorities

There is a wide range of strategies and policy agendas which will influence the direction of this strategy. This includes (among many others) the Outcome Improvement Plan; HITRANS Electrical Vehicle Strategy; Climate Change Plan the Third Report on Proposals and Policies 2018-2032; Argyll and Bute Corporate Plan and The Community Planning Partnership's (CPP) 2012-2023 and the Decarbonisation Plan 2021.

The Climate Change (Emissions Reduction Targets) (Scotland) Act 2019, which amends the Climate Change (Scotland) Act 2009, sets targets to reduce Scotland's emissions of all greenhouse gases to net-zero by 2045 at the latest, with interim targets for reductions of at least 56% by 2020, 75% by 2030, 90% by 2040¹

Argyll and Bute relies heavily on vehicle transport therefore it is vital that greener solutions are developed in order to work towards Climate Change targets as well as ensuring we are delivering social, economic and environmental benefits to communities across the area. This strategy sets out the vision that Argyll and Bute Council has to help the Scottish Government meet their ambitious target for Scotland to phase out the need for new petrol and diesel cars and vans, initially by 2032 however the update to the 2018-2032 Climate Change Plan published in December 2020 updated this to 2030 bringing this ambition forward from the 2018 Plan by 2 years, in line with the Climate Change Committee's recommendations in its 2020 Progress Report to the Scottish Parliament.

It is important that the strategy should be closely aligned with the Outcome Improvement Plan (previously the SOA) and Community Plan for Argyll and Bute, as well as supporting a range of other local plans and strategies.

The Outcome Improvement Plan sets the vision for achieving long term outcomes for communities in Argyll and Bute. Sustainability and Infrastructure are sighted s a challenges for the area; ensuring a sustainable future by protecting the natural environment and mitigating climate change and improving and making better use of infrastructure in order to promote the conditions for economic growth including enhancing the built environment and our town centres. This in turn links into national policy priorities for community planning; outcome 2 *infrastructure that supports sustainable growth*. Within the next 10 years the vision is that the development of the electrical transmission and distribution grid has been strengthened to support the continued development of renewable technology and to provide additional community resilience².

Climate Change Plan Policy Outcome 2 *the proportion of ultra-low emission new cars and vans registered in Scotland annually to reach 100% by 2032* will be achieved through 8 different policies and four proposals, which are shown in the table below:

¹ <https://www.gov.scot/policies/climate-change/reducing-emissions/>

² https://www.argyll-bute.gov.uk/sites/default/files/aboip_v1_2018.pdf

Policies which contribute to the delivery of policy outcome 2	Policy proposals which contribute to the delivery of policy outcome 2
1) With the EU and UK, negotiate stretching emission standards for new cars (and vans) beyond 2020	1) Consider draft proposals in the Energy Performance of Buildings Directive (EPBD), relating to the provision of EV charge points/wiring in new residential and commercial developments. Investigate how such measures could potentially be trialled in Scotland and consider developing guidance on charge point provision to support planning authorities.
2) With the UK, negotiate Vehicle Excise Duty differentials between ultra-low emission vehicles (ULEVs) and diesel/petrol vehicles to support and encourage the uptake of ULEVs	2) In advance of a decision as to whether charging points will be a feature of building standards, Transport Scotland will consider developing guidance on charge points to support planning authorities
3) Enhance the capacity of the electric vehicle charging network (ChargePlace Scotland)	3) Continue to investigate the role that other alternative fuels, such as hydrogen, gas and biofuel can play in the transition to a decarbonised road transport sector. Consider the scope for market testing approaches to alternative fuels infrastructure and supply.
4) Provide interest-free loans through the Energy Saving Trust to enable the purchase of EVs by both consumers and businesses until at least March 2020.	4) Work with Scottish Enterprise, the UK Government, and other bodies to investigate the potential to undertake trials of connected and autonomous vehicles in Scotland.
5) With local authorities, review licensing regulations and consider introducing incentives to promote the uptake of ULEVs in the taxi and private hire sector, with loan funding for vehicle purchase until at least March 2020	
6) Promote the benefits of EVs to individuals and fleet operators (exact nature of promotion to be decided annually).	
7) We will support the public sector to lead the way in transitioning to EVs, putting in place procurement practices that encourage EVs.	
8) We will establish by 2019 an innovation fund to support innovation in business, academia and industry around EV adoption.	

3

³ Scottish Government Climate Change Plan; the third report on proposals and policies 2018-2032

Specifically of interest is Policy No 3: *Enhance the capacity of the electric vehicle charging network (Charge Place Scotland)* via:

- continuing to grow the network up to 2022 (plans cover a 10-15 year period from publication)
- providing support for home charge points for consumers
- providing support for workplace charge points work with each of our delivery partners to create Scotland's 'Electric A9', including charging points along the route and demonstrating that electric vehicles offer important advantages to motorists in rural and urban Scotland
- providing funding for towns and cities to become 'Switched On' – working with partners, local authorities will get funding to meet local EV transition needs such as supporting charging initiatives for tenements and EV incentives

Working towards this, Argyll and Bute Council accessed capital funding for electric vehicle charging infrastructure of which over £700,000 was secured for the area. The funding paid for the acquisition and installation of 24 charging points and the extent of the current network, not only across Argyll and Bute but across Scotland can be viewed at <https://chargeplacescotland.org/>.

This strategy will also link directly into the Corporate Plan mission of *being a place that people choose to work and do business, corporate infrastructure that supports sustainable growth* and business outcomes BO113; *our infrastructure is safe and fit for the future* and BO114; *our communities are cleaner and greener which will assist the council to meet the mission of argyll and Bute being a place*⁴

In addition the HITRANS strategy which sets out a vision that the HITRANS region will be at the forefront of achieving national commitments for low emission transport, communities across the region⁵. HITRANS (Highlands and Islands Transport Partnership) is the regional transport partnership covering Western Isles, Orkney, Highland, Moray and most of the Argyll and Bute area; Helensburgh and Lomond is covered by SPT.

As vehicle ownership in the HITRANS region is 18% higher, and average distances travelled by road are estimated to be around 20% higher than the Scottish average investing in Electric Vehicle Chargers provides an opportunity to enhance the connectivity of people to each other and remove barriers to accessing employment, education, leisure activities and essential services. The low population densities in the area mean that private car use will remain a necessary mode of transport for many people and businesses.

The Councils Decarbonisation Plan is another document that this strategy must consider. The plan not only seeks to highlight work undertaken by the Council and promote planned activities but also to act as a route map for our journey towards net zero; the aim is to *achieve 75% carbon reduction by 2030 and net zero before 2045*; this aligns with national requirements. *Support low carbon economy* by assisting local communities and businesses to recover and build upon our low carbon economy.

⁴ https://www.argyll-bute.gov.uk/sites/default/files/corporate_plan_2018_181119_v2_0.pdf

⁵ HITRANS Electric Vehicle Strategy

Lead by example and develop practices and partnerships that inspire low carbon behaviours by seeking to be innovative, collaborative and ambitious with our climate change actions that inspire others and tackle impacts together. Make 'Climate Friendly Argyll and Bute' a recognised brand and underpin behaviours of our staff and customers by using the new branding to underpin messages of our Decarbonisation Plan⁶.

With the Scottish Government ambition to phase out the need for new ICE (internal combustion engine) vehicles by 2032, it is expected that sales and use of electric vehicles (EVs) will grow rapidly over the next ten years. These rates of growth also have the potential to significantly increase the electricity consumed across the regions charging infrastructure therefore a key consideration of the future installation criteria must be to ensure electricity provisions are adequate in each area chargers are to be installed, while balancing considerations like capital investment to upgrade electricity supplies against the need to have an equitable provision across the council area. Providing a consistent experience for EV users will help simplify their use and support widespread adoption. The remote nature of the area also increases the cost to move goods so with lower operational costs, the use of EVs represents a significant opportunity to increase the competitiveness of local businesses. However, this will only be achieved if the infrastructure and services that facilitate this change reflect regional transport patterns. This will require coordinated planning and operation between local authority regions; this joint working will be co-ordinated by HITRANS and any relevant publications will be reflected in future updates of this strategy.

2. Understanding electric vehicles and chargers

Before the charging regime is set out it may be helpful to understand the basic workings of electric vehicles, this section provides information and clarification on the workings of electric cars and examples of the different types of batteries and currently available.

An electric car charger is an appliance that charges an electric or hybrid plug-in car, as the industry is relatively new, EV car chargers are known by a few different names and commonly referred to as electric car charging stations, electric car charging points, EV wall chargers and wall boxes. Charging an electric vehicle is not that different from refuelling in the traditional way. There is a fuel cap however instead of petrol tank there is a charging socket where you plug in the connector. Once a vehicle charges to 80% the rate will slow down to reduce the battery heating, and will generally only reach 100% charge if left charging overnight. Rapid chargers begin to 'taper' i.e. to reduce the power they deliver as EVs have sophisticated battery management systems which protect the batteries from over-charging and from charging too rapidly, both of which can cause damage, here are the charges located in Dunoon and Lochgilphead as an example:

⁶ Argyll and Bute Council Decarbonisation Plan 2021



There are 3 different types of electric vehicles; the BEVs (Battery Electric Vehicle) are powered by electricity alone. They are zero-emission while driving. PHEVs (Plug-in Hybrid Electric Vehicles) combine the power of both a petrol engine and an electric motor. In MHEVs (Mild Hybrid Electric Vehicles) the petrol engine is supported by an electric motor. The electric motor allows the car's engine to switch off when coasting, braking or stopped, and quickly turns it back on when needed⁷.

There is yet to be a universal connector for electric vehicles and the various chargers, EV will be supplied with a cable that has the plug it requires, and at charger the cables are all compatible⁸. EV users can select between 2 connection types, either an AC or DC charger. AC chargers can be found in service stations, parking spaces, residential and commercial sites. The type 2 (Mennekes) socket is a European standard EV connection. While DC chargers are found in the same locations as the ACs with the exception of services stations, instead they are found in highway service areas. There are three DC plug types available on the market (not including Tesla) that car manufacturers have standardised on CCS2 or Combo 2 is a combination of a Type 2 (Mennekes) plug and 2 DC pins, CCS1 also is a combination of a Type 1 (J1772) plug and 2 DC pins, illustration of each shown below:

⁷ SEAT UK - All about electric

⁸ Electric car charging – how it works and how much it costs | RAC Drive

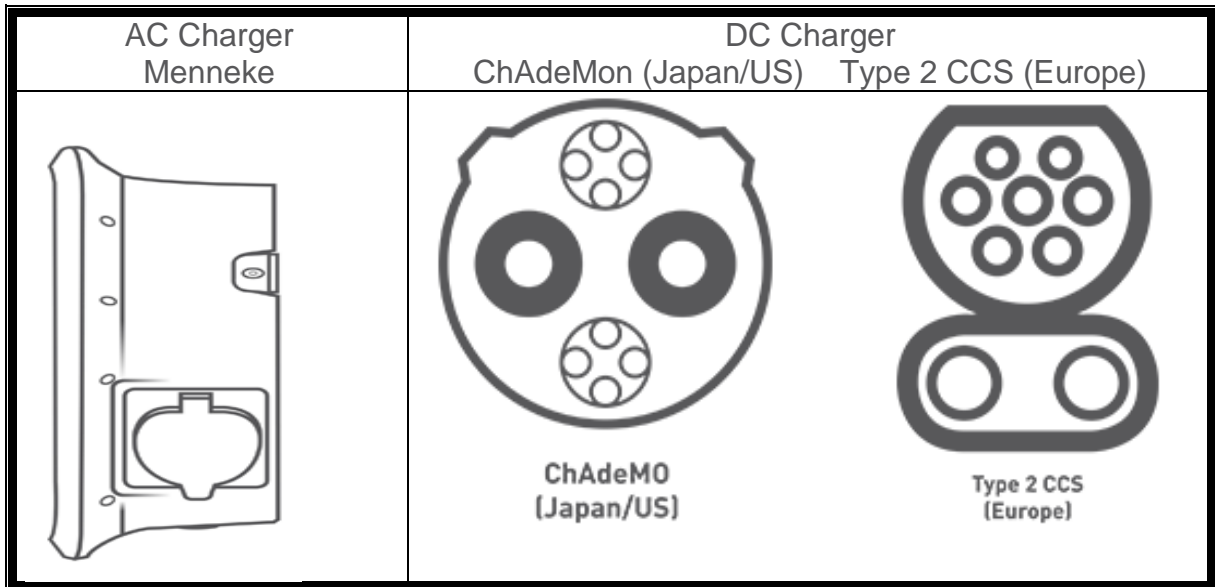

The difference between the two being the DC current directly charges the batteries in the electric vehicles, as opposed to AC chargers which utilise the rectifier in the vehicle to turn AC from the supply into DC to charge the battery. In most cases, the rectifier in the vehicle is limited to between 3 and 11 kW, using a single phase of AC power⁹.

There are different speeds of charger, slow, fast and rapid however the length of time it takes to charge an EV battery depends on the battery itself and the type of charger; which are powered by kilo watt (kW). Slow chargers empty to 100% and typically takes around 5-8 hours for most EVs rising to around 12 hours for longer range cars with larger batteries and tend to come in 3 – 6 kW. Fast chargers range in kW also, a 7kW fast charger can charge an EV in 3-5 hours, while a 22kW unit could complete the task in a couple of hours. Using a rapid charger typically takes around 45mins – 1 hour for an 80% charge, rising to around 1.5 hours for the longer range EVs with larger batteries, a 15 minute charge using a rapid charger typically gives a 30-40 mile range.¹⁰ Rapid DC chargers usually provide up to 50kW of power, while rapid AC units are rated up to 43kW

'Range anxiety' is a big fear for people and maybe one of the reasons the move to electric vehicles has not been greater. Range anxiety is the fear that a pure electric vehicle has insufficient range on a fully-charged battery to safely reach your destination. As a typical EV range is between 100 – 300 miles this is becoming less of an issue as the UK's charging infrastructure catches up with demand. Zap-Map reports that there are 31,737 charging points at 11,377 different locations across the UK as of May 2020, this document sets out how Argyll and Bute Council will strive to contribute towards the growing network.

⁹ Commercial Chargers (rapidcharge.com)

¹⁰ Electric car charging – how it works and how much it costs | RAC Drive

3. Charging Regime

In relation to the charging regime there are various elements to consider in order to set the cost, for example Aberdeenshire City Council applied 3 criteria to ensure all costs are covered; cost of energy, cost of maintenance and cost of transaction which includes administrative and management fees.

A review of charging models used in other Local Authorities suggests there are three main options for charging for the use of EV charge points:

- a) Fixed Rate: A single rate is charged regardless of amount of energy drawn – a fixed rate is not equitable – customers would be likely to lose out as a result of this model which could leave the Council open to criticism.
- b) Fixed Rate Plus Costs: A fixed rate is charged to use the charge point and customers are also charged per unit of electricity consumed; - this model provides certainty over coverage of fixed and variable costs, and transparency for users.
- c) Costs Only: Customers are charged per unit of electricity used [which means a tiered system depending on the type of charger] used. – this option may expose the Council to financial risk inasmuch as it does not provide for coverage of fixed costs.

After considering the available cost recovery options, it is considered that Option B offers the most equitable charging model and best financial protection for the Council. Incorporating variable costs to the Council (energy, maintenance,) and a cost per kW unit of electricity consumed allows for full cost recovery to be borne equally by all customers based on actual usage.

For Argyll and Bute when setting the unit cost the price paid for energy must be taken into account as this differs depending on the voltage available in each area, which in practice means the cost to the Council of each individual charger is likely to vary somewhat from location to location and some sites will make a profit while others will not.

Clearly it would be both unreasonable and administratively burdensome to charge a different rate in each location, although it has to be acknowledged that a small number of sites may operate at a loss due to the standing electricity costs at the location vs the demand however as EV popularity grows over the coming years this may not always be the case but at this time it is unavoidable as the Council could not disadvantage smaller and more rural settlements by setting higher charges to avoid this situation.

As with many areas of the Council's business, it is expected that while the charging model may not stack up site per site, when considering the entire network as a single entity, then the model should allow us to 'break even'.

The Council is aware of a few other local authorities that have introduced charging but these regimes are variable, for example, Moray Council is charging a flat fee of £3.80 for each charging session irrespective of charge type while Orkney and Dumfries and

Galloway Councils are charging 25p per kWh as a flat rate. There is also a private developer in Edinburgh proposing to charge a flat rate of £10 *per hour* irrespective of the type of charger or how long the charging time¹¹

Electric Vehicle Association (EVA) Scotland support a differential between Fast and Rapid chargers of a minimum of £0.03 per kWh used and recommend that the differential not exceed £0.10 while Transport Scotland recommended that a per kilowatt hour (kWh) charge is preferable. In addition to this some local authorities found there was another option of charging price per minute rather than kWh for rapid chargers. This is a useful tool to assist when calculating the cost to use publically accessible charging sites; Public charging calculator - how much does it cost to charge an electric car? (zap-map.com)

The average home electricity rate is about 14.4p per kWh, but depends on the specific energy tariff. Then, as a rough guide, you need to multiply this by the size of the vehicle's battery. For example, Mii electric has a 36.8kWh battery so at 14.4p per kWh it could cost around £5.30 to fill up¹².

Applying a connection fee is thought to be counter-productive by EVA Scotland they state such a fee encourages behaviour that is unlikely to support optimum utilisation and availability of charge points. Users tend to maximise their stays to minimise the unit cost. Instead they recommend a minimum fee for charger use being around £1, or at least cost neutral¹³. However Edinburgh City Council believe connection charges are required to enable the programme to become self-financing¹⁴.

It is thought, at this time it would be best not to implement a connection fee, EVC users will simply pay for electricity used, maintenance, administrative and management fee. It is important to acknowledge that should the model prove not to be financially viable after review we may have to revisit the application of a connection charge

3.1 Cost Breakdown

All options set out below will incur a cost that will be partially covered by the funds generated by EV chargers, the following table sets out what financial impact the Council has absorbed over the years for providing free EV charging:

Year	Financial Impact	Total kWh
2018/19	£15,605.80	62808.74
2019/20	£21,185.29	122188.1
2020/21	£32,875.46	253551
Total	£69,666.55	474959.6

Both aspects shown in graph format below:

¹¹ https://democracy.edinburgh.gov.uk/documents/s11552/Electric_Vehicle_Programme_-_Referral_to_TEC_Full.pdf

¹² [Electric Cars - FAQs | SEAT UK](#)

¹³ EVA SCOTLAND TARIFF GUIDANCE Billing for Public and Private EV Charging

¹⁴ [Electric_Vehicle_Programme_-_Referral_to_TEC_Full.pdf \(edinburgh.gov.uk\)](#)

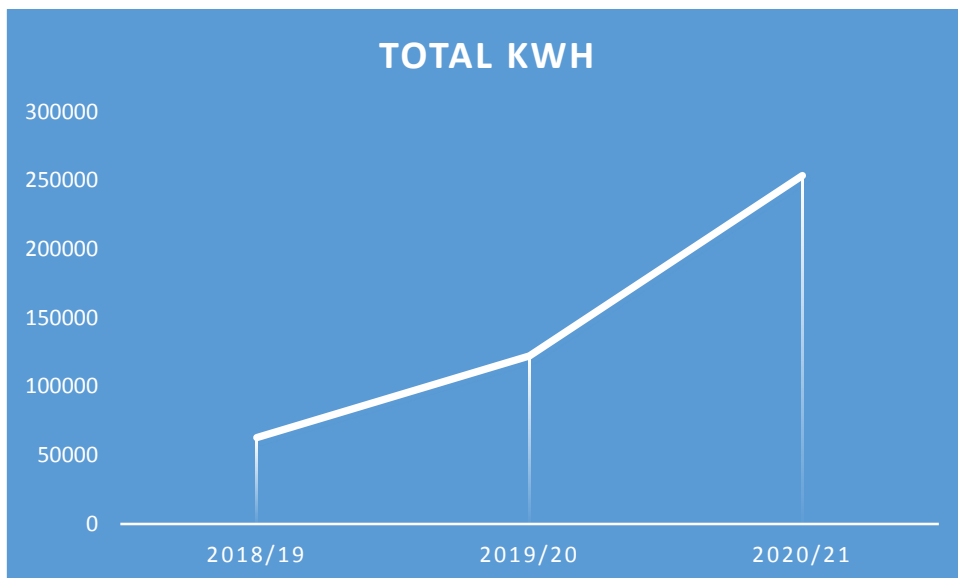
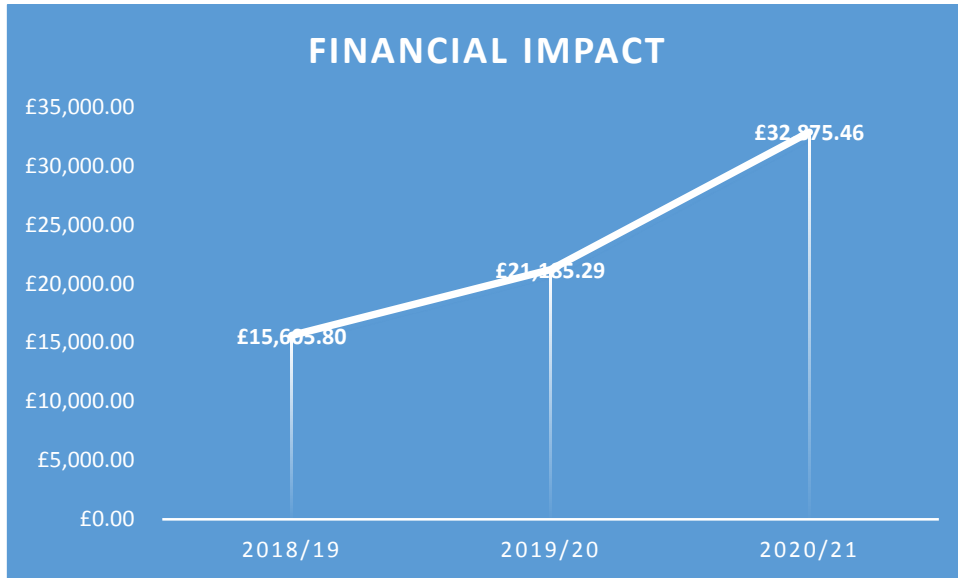

As a rough guide, an electric car charging overnight to full can cost as little as £5.30* the electric Mii has a battery capacity of 36.8kWh. Therefore based on the UK average electricity price of 14.4p per kW it costs £5.30 to fully charge from empty, as of May 2020¹⁵

The following table illustrates various makes of EVs and the associated costs for each:

¹⁵ SEAT UK - All about costs

Car Type	Range (miles)	Electric cost / mile
Audi A7	31	6.74p
BMW 330e iPerformance	37	6.29p
Citroen A5 Aircross	34	5.76p
Citroen C Zero	93	3.33p
Ford Focus Electric	139	4.67p
Mercedes B250e Electric	124	4.85p
Mercedes EQC	259	5.14p
Renault Zoe Q90 ZE40	174	4.57p ¹⁶

The following table sets out the 2021/22 costs for an EV driver to access a charger in Argyll and Bute:

	Net	VAT	Gross
kWh and Maintenance - Charge based on 20p to cover Council's electricity costs and 1p to contribute to future maintenance costs	£0.21p	£0.04	£0.25
Minimum Charge - covers management costs e.g. admin, banking fees, merchant fees etc - CPS recommend £1.50 minimum charge which would cover the transaction fees, please note this is a minimum charge, not a connection fee	£1.50	£0.30	£1.80

The following table sets out what charges, to the Council, will be covered from the costs to EVC user:

CPS Transaction Fee	0.36p inc VAT
CPS Banking Fee	2.95% of total cost of charging session (Including VAT)
Merchant Fee	1.50% of total cost of charging session (Including VAT)

¹⁶ [Electric Vehicle Guides | Pod Point \(pod-point.com\)](http://pod-point.com)

4. Enforcement Penalties

In order to give EV users confidence that parking bays will be available when required and that bays will be used correctly, only by electric vehicles, a new enforcement penalty is required which ideally would be based on current parking enforcement practices, and this would be payable directly to the Council in the current way that parking penalties are issued.

Separately any overstay fee occurred is added to the invoice of the Charge Place Scotland (CPS) account holder¹⁷; CPS is the current contractor appointed by Transport Scotland to provide a “back office” function including management of all software and administrative functions that enable reporting of faults, collection of payment and collation of data. A ten minute grace period will apply, any one user ending charging within the period would not be charged, but as soon as the overstay exceeds that ten-minute window a £30 penalty will be applied. The fees will be collected as part of the standard transaction through the Charge Place Scotland management system.

The enforcement regime will be a key element to enforce exclusivity, this will be carried out by the Council’s parking wardens who will ensure that only EV’s will be able to use the charging bays. Under the new regime, any non-electric vehicle parking in an EV bay will incur an immediate fixed penalty notice and any EV occupying a charging bay but not charging will also incur a fixed penalty. Parking attendants will know the locations of all Council owned chargers and be able to monitor their use as part of the normal course of their duties.

In line with other local authorities a new maximum stay and no return periods will also be introduced to ensure that charging bays are available as much as possible. Penalties will be applied to any EV user who stays in the charging bay past the maximum stay period. The table below summarises the new procedures:

Charger Type	Main Users	Max Stay Apply After
Slow (7kW)	Commuters	No max stay
Fast (22kW)	Residents / General Use	4 hrs
Rapid (50kW)	Residents / General Use	2hrs

Different criteria for different EV chargers is appropriate, at this time no overstay period will apply to slow chargers as these can take around 12 hours to fully charge. This potentially allows two cars to charge within a 24 hour period if required. In contrast, the much shorter maximum stay periods are applied to rapid chargers, where these vehicles can take around 90 minutes for a charge enabling a more “topping -up” approach. Quicker turn-around times can ensure maximum use of these charging bays throughout the day. Below is information on approximate charge time, bear in mind that regardless of the power of the charger itself, the car will only be able to charge at the maximum rate of its on board system:

¹⁷ <https://chargeplacescotland.org/helpcentre/accounts-and-payments/>

Charge Type	Approximate Charge Time for a car with a 40kW battery
Slow (7kW)	12 hours
Fast (22kW)	4 hours
Rapid (50Kw)	90 mins - 2 hour

¹⁸

Charge Place Scotland have confirmed that they will be able to support aspects of the Council's enforcement policy by being able to monitor both maximum stay and no return periods. The charges will be recovered to the Council via a recharge arrangement with CPS.

4.1 Traffic Regulation Orders

Another element of the enforcement regime is to include Traffic Regulation Orders (TROs) which allow the Council to designate part of the carriageway or off-street car park for use by a certain group of vehicles, TROs support the enforcement of issuing penalty notices to those who park in contravention of the regulations. Discussions with roads and amenity have confirmed there are currently separate TROs for all carparks in Argyll and Bute, in the near future it is hoped each admin area will have a standard TRO; when these are being updated the EV charging point enforcement section will be updated.

The table below details the future enforcement role of the Traffic Attendants and the penalties that will be applied, all vehicle users will be subject to these additional penalties if they fail to adhere to the new enforcement regime:

ROLE	ENFORCEMENT RESPONSIBILITY	PENALTY
Council Traffic Attendants	If non EV car parked in charging bays penalty applies	£60.00 fixed penalty reduced to £30 if paid within 14 days. If paid after 28 days the fine increases to £90
Council Traffic Attendants	EVs must be plugged into charger and not just using bay for parking	SAME penalty as above.

¹⁸ [How long does it take to charge an electric car? | Autocar](#)

5. Potential future costs

In addition to supply and installation; maintenance, software updates, bay markings, signage, protective barriers, connection to Charge Place Scotland and provision of sim and connectivity; warranty covering repairs and parts, software upgrades, feeder pillar, earth pit, switch fuse/RCD and connection to RCD unit are covered within the capital grant therefore there is no additional outlay for the Council for the provision of these until the warranty period ends. The manufacturer warranty reduces the true understanding of long term maintenance and replacement costs at this time.

There are a range of options to consider in order that we might mitigate the potential future costs such as utilising internal resources for servicing and repairs (subject to suitable training), extending warranty contracts with existing providers, or engaging existing Council term contractors to service machines routinely in each locality, or entering into a single maintenance contract.

Although potential future maintenance cost implications are not known at this time there will be a cost to the Council; for officer time of researching these costs and developing the most appropriate and cost effective future maintenance programme. It is therefore not unreasonable to include within the overall fee proposals an element to cover the officer time involved, suggest 1p / kWh. This charge would be implemented from date the charging model goes live to cover time spend to date developing the charging model.

HITRANS have highlighted the remote nature of the region presents challenges to manufacturers and suppliers in maintaining infrastructure. This has reduced the ability to quickly respond to faults; to address this Highland Council, working with charge point manufacturers, are training members of its electrical team to undertake common repairs to charging infrastructure¹⁹. Should Argyll and Bute Council explore this option and use internal resources we would be able to offer maintenance services to neighbouring authorities or external organisations i.e. NHS or Argyll College who have installed private chargers, thus resulting in potential additional Income to the Council and good coverage to the whole EV network.

In preparation for future proofing Council mechanics have already completed EV training course through Glasgow Training Group in order to be able to service the Council's EV fleet and the possibility of training either mechanics or street lighting team in order to have resources in house to service the EVC's will be further investigated over the course of 2021/22.

¹⁹ HITRANS ELECTRIC VEHICLE STRATEGY

5.1 Charging review

At this time fees have been calculated based on information gleaned from CPS and guestimates on future maintenance costs, these will have to be revived periodically to ensure the cost model applied is suitable.

We will require to review the income levels achieved from our charging model to ensure that the Council's current and potential future costs can be covered. We will receive returns from CPS quarterly and will track income against expenditure in each quarterly period, and report on any particular variances as required. Should the charging model need to be amended for future years, this will be the subject of a future report prior to fees and charges being proposed in the normal Council budget process.

*****ENDS*****